

System 420

Continuous Tube Conveyor

TAB UP



System 420

Is designed for conveying garments & similar items on wire hangers, horizontally, on inclines or both; in all directions and to follow almost any desired path.

- ◆ Enclosed Track, Zinc Plated or Stainless Steel.
- ◆ Stainless Steel Turns, Hardened & Machined slot.
- ◆ Hardened *Corrosion Resistant* Links & Pusher/Carrier.
- ◆ Combined Link & Pusher/Carrier.
- ◆ Torque Limiter Overload Protection, Chain Pull - 500 lbs.
- ◆ Temperatures to 300° F., Humidity to 100%

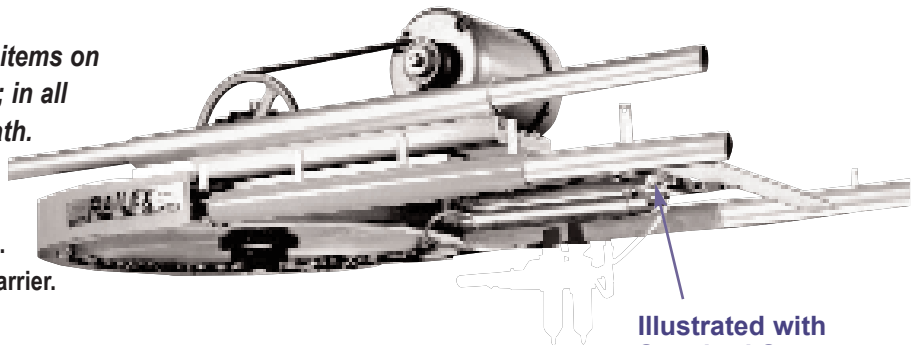

Illustrated with
Standard Screw
Take-up

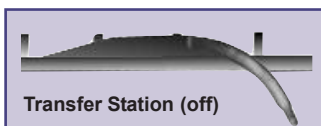
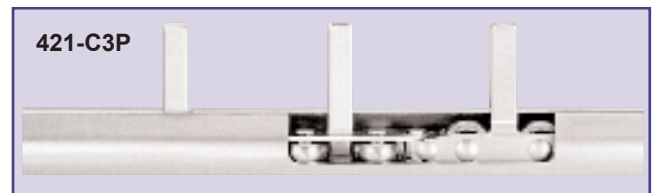
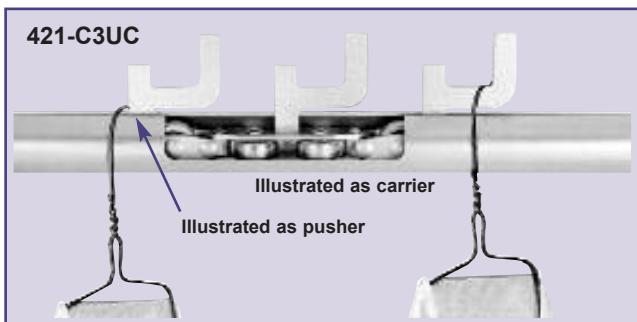

G2 -
Rail
Support

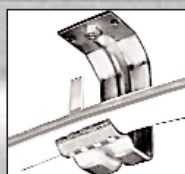

CB2 -
Rail
Support

Stainless Steel or Zinc Plated Steel
1 5/16" O.D.. - 12 ga. Lengths to 20 ft.



89-02 Atlantic Ave., Ozone Park, NY 11416
 Tel: (718) 845-5454 ☎ Fax: (718) 738-1020
 WWW.RAILEXCORP.COM

STAINLESS STEEL CURVES

Hardened, Machined Slot

**Radius - 18" & 24" Standard
 12", 13", 15", to order**

Tangents 12"

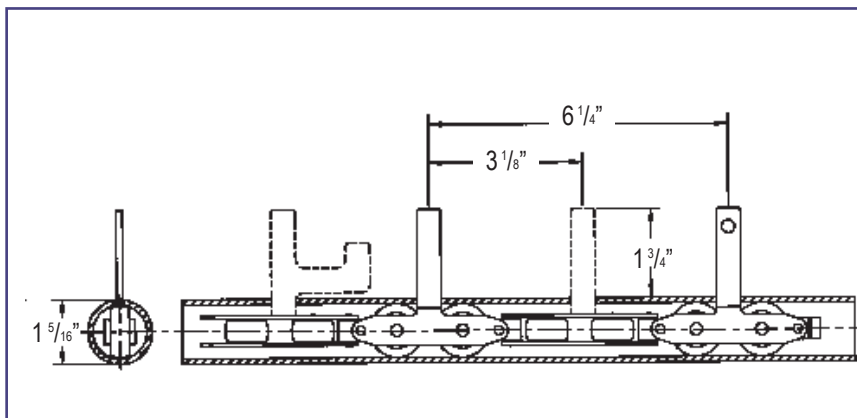
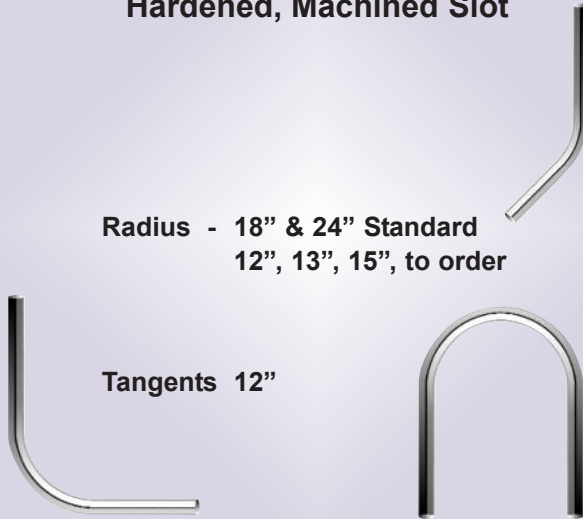

STANDARD COMPONENTS

TRACK & CHAIN

421 - 20ZP	Track, Slotted, Zinc plated 20 ft.
421 - 20SS	Track Stainless Steel 20 ft.
421 - C6P	Chain, Pusher 6 1/4"
421 - C3P	Chain, Pusher 3 1/8"
421 - C3UC	Chain, U-Shape Carrier 3 1/8"

CURVES 18" & 24" RADIUS STANDARD

422 - 15H Curves, Stainless Steel	15° Horiz.
422 - 30H	30° Horiz.
422 - 45H	45° Horiz.
422 - 60H	60° Horiz.
422 - 90H	90° Horiz.
422 - 180H12	12" r, 24" dia. 180° Horiz.
422 - 180H18	18" r, 36" dia. 180° Horiz.
423 - 15V U or L	15° Vert.
423 - 30V U or L	30° Vert.
423 - 45V U or L	45° Vert.
423 - 60V U or L	60° Vert.
423 - 90V U or L	90° Vert.

TRANSFER STATIONS

424-TF ON-L/R	Transfer Station, Fixed, On
424-TS ON-L/R	Suspended, On
424-TF OFF-L/R	Fixed, Off
424-TS OFF-L/R	Suspended, Off
424-TP OFF	Pneumatic, Off
424-TSPON	Pneumatic, On

DRIVE UNITS-180° Fixed Speed with Screw Take-Up

425-D18012	12" 18-45 fpm
425-D18018	18" 28-45 fpm
425-D18024	24" 36-45 fpm
425-MODLSR	Low Speed Reduction
	12" under 18 fpm
	18" under 28 fpm
	24" under 36 fpm
425-VSE.50	Variable Speed Elec.

IDLERS

425-I18012	Idler 180° 12" Diam.
	18"
	24"
427-WC	Welding Clamp
427-LUBE	Lubricant 14oz.

