

METHOD OF SUSPENSION FROM JOISTS PARALLEL TO CONVEYOR
1" = 1'-0"

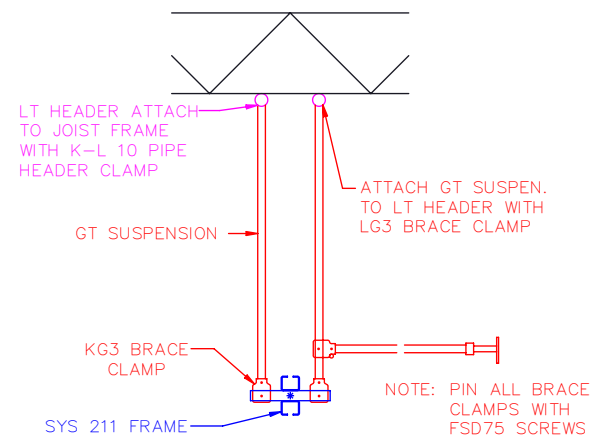

METHOD OF SUSPENSION FROM JOISTS PERPENDICULAR TO CONVEYOR
1" = 1'-0"

CHECK AND ADJUST RAIL SUPPORTS FOR PROPER DISTANCE FROM CONVEYOR TRACK. (SHOWN FOR RAILEX 510 & 810 TROLLEYS)

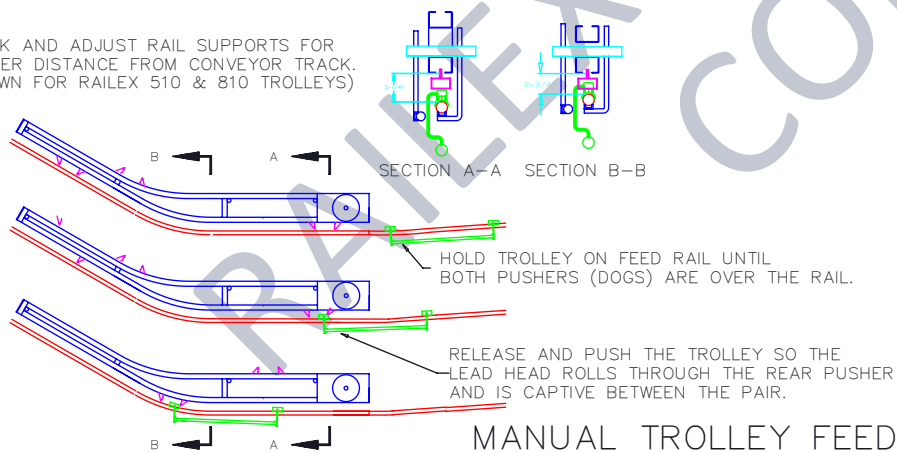

MANUAL TROLLEY FEED

DESCRIPTION:

RAILEX SYSTEM 211 TYPICAL TROLLEY BOOSTER POWER RAIL FOR GOH ELEVATION CHANGE

DWG. #

96011

NOTICE: THIS DRAWING AND DESIGN IS THE SOLE PROPERTY OF RAILEX CORP.



RAILEX CONVEYOR CORPORATION

T. 718-845-5454

railex@railexcorp.com

www.railexcorp.com